

# User Manual



## PAPER SHREDDER WITH AUTOMATIC FEED



# QR codes take you where you want to go quickly and easily

Whether you require **product information, spare parts** or **accessories**, details on **warranties** or **aftersales services**, or if you want to watch a **product demonstration video**, our QR codes will take you there in no time at all.

## What is a QR code?

A QR code (QR = Quick Response) is a type of matrix that can be read with a smartphone camera and that contains a link to a website or contact details, for example.

**Advantage:** You do not need to manually enter a website address or contact details.

## How it works

To scan the QR code, all you need is a smartphone with QR code reader software and an internet connection. This type of software can be downloaded for free from your smartphone's app store.

## Try it out now

Just scan the QR code with your smartphone and find out more about the Aldi product you have purchased.

## Your Aldi Service Portal

All details mentioned above can also be found in the Aldi Service Portal at [www.aldi.com.au](http://www.aldi.com.au).



Depending on your tariff plan you may be charged for the connection.

# Contents

<b>Overview .....</b>	<b>4</b>
<b>Use.....</b>	<b>5</b>
<b>Product contents / device parts.....</b>	<b>6</b>
<b>General information.....</b>	<b>7</b>
Reading and storing the user manual .....	7
Explanation of symbols .....	7
<b>Safety .....</b>	<b>9</b>
Proper use.....	9
Safety instructions.....	9
<b>First use.....</b>	<b>14</b>
Checking the paper shredder and pack contents.....	14
Assembly.....	14
<b>Start-up.....</b>	<b>15</b>
<b>Using the paper shredder.....</b>	<b>15</b>
Automatic paper feed slot .....	17
Manual paper feed slot .....	17
Credit card feed slot.....	18
<b>Emptying the waste bin.....</b>	<b>18</b>
<b>Paper or credit card jam .....</b>	<b>19</b>
<b>Fault LEDs .....</b>	<b>19</b>
<b>When not in use .....</b>	<b>20</b>
<b>Cleaning and maintenance.....</b>	<b>20</b>
Cleaning the housing.....	21
Cleaning the cutting unit .....	21
<b>Storage .....</b>	<b>22</b>
<b>Troubleshooting.....</b>	<b>22</b>
<b>Technical data .....</b>	<b>23</b>
<b>Declaration of conformity .....</b>	<b>24</b>
<b>Disposal.....</b>	<b>24</b>
Disposing of the packaging .....	24
Disposing of old appliances .....	24
<b>Warranty details.....</b>	<b>25</b>
<b>Repair and refurbished goods or parts notice .....</b>	<b>26</b>

A

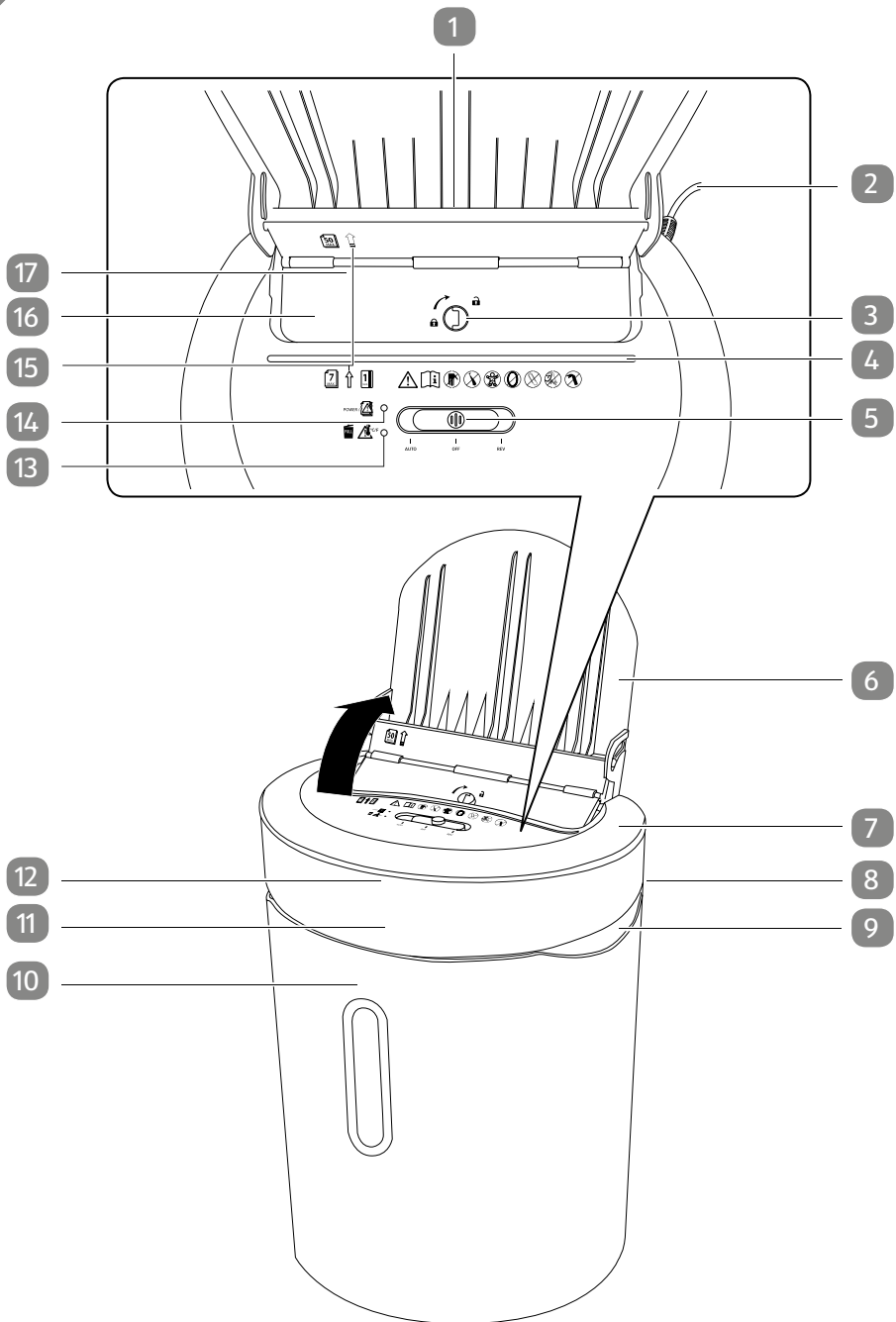

B

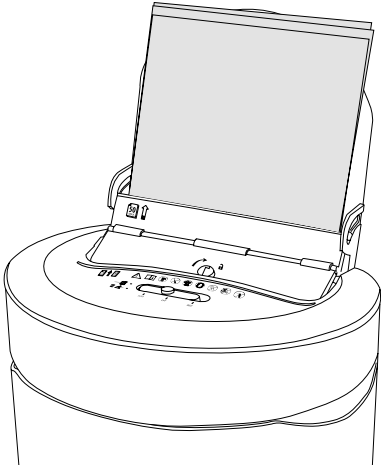

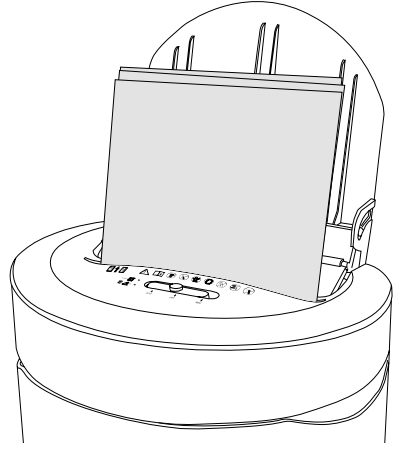

C

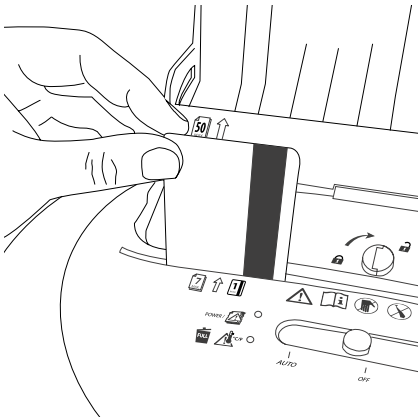

D



## Product contents / device parts

- 1 Automatic paper feed slot (for max. 50 sheets, A4, 80 g / m<sup>2</sup>)
- 2 Power cord
- 3 Twist lock
- 4 Manual paper feed slot (for max. 7 sheets, A4, 80 g / m<sup>2</sup> / credit card feed slot)
- 5 Slide switch (AUTO / OFF / REV)
- 6 Cover lid / paper support
- 7 Main unit
- 8 Safety contact (on the inside)
- 9 Carrying handle for the main unit, 2×
- 10 Waste bin
- 11 Fill level sensor (on the inside)
- 12 Cutting unit (on the inside)
- 13 Emptying LED () / overheat LED ()
- 14 Power LED (POWER) / overload LED ()
- 15 Arrow for sensor position, 2×
- 16 Shutter for the main unit
- 17 Paper sensor (on the inside)

# General information

## Reading and storing the user manual



This user manual accompanies the paper shredder with automatic feed (hereinafter referred to only as the “paper shredder”) and it contains important information on start-up and use.

Carefully read through the user manual before using the paper shredder. This particularly applies to the safety instructions. Otherwise, you could injure yourself or damage the paper shredder.

Store the user manual for further use. If you pass the paper shredder on to third parties, be absolutely sure to include this user manual.

## Explanation of symbols

The following symbols and signal words are used in this user manual, on the paper shredder or on the packaging.

**⚠ WARNING!**

This signal symbol / word designates a hazard with moderate risk, which may result in death or severe injury if not avoided.

**⚠ CAUTION!**

This signal symbol / word designates a hazard with low risk that, if not avoided, may result in minor or moderate injury.

**NOTICE!**

This signal word warns against potential damages to property.



This symbol provides you with useful supplementary information on use.



Declaration of conformity (see chapter “Declaration of conformity”): Products marked with this symbol meet all applicable regulations for the European Economic Area.



The symbol indicates that the construction of the product corresponds to the protection class II (double insulation). A safety connection to the electric ground is not necessary.



Only use the paper shredder indoors.



The RCM Mark (Regulatory Compliance Mark) indicates that the product complies with the relevant guidelines of the ACMA as well as corresponding government requirements for the safety of electrical devices.



Important safety information.



Before using the paper shredder for the first time, carefully read through the user manual and hold onto it for subsequent reference.



Do not insert more than 50 sheets of paper in the automatic paper feed slot (A4, 80 g / m<sup>2</sup>)!



Do not insert more than 7 sheets of paper in the manual paper feed slot (A4, 80 g / m<sup>2</sup>)!



Only insert one credit card into the credit card feed slot at a time!



Do not reach into the paper feed slots with your hands!



Keep loose clothing such as ties and scarves away from the paper feed slots!



Do not allow children to play with the paper shredder. The paper shredder may only be used by children if they are supervised by adults!



Make sure that accessories that hang down (such as necklaces) do not come near the paper feed slots.



Make sure that no paper clips, staples or similar end up in the paper feed slots of the paper shredder.



Keep long, loose hair away from the paper feed slots!





Do not use any spray cans / aerosols near the paper shredder!



Never use the automatic and manual paper / credit card feed slot at the same time! Only insert the maximum allowed amount of paper in the corresponding paper feed slot.



The waste bin holds 21 litres. Once the fill level is reached, the paper shredder automatically stops.



The paper shredder is not designed for continuous operation! The paper shredder automatically switches off if it overheats as the result of continuous operation. Do not use the manual paper feed slot for more than 3 minutes and the automatic paper feed slot for more than 7 minutes.



To open the main unit, turn the twist lock from left to right.

## Safety

### Proper use

The paper shredder is only designed for shredding paper and credit cards. It is only intended for private use and is not suitable for commercial use.

Only use the paper shredder as described in this user manual. Any other use is considered improper and may result in damage to property. The paper shredder is not a children's toy.

The manufacturer or vendor accepts no liability for damage caused by improper or incorrect use.

### Safety instructions

#### **⚠ WARNING!**

#### **Risk of electric shock!**

A faulty electrical installation, excessive mains voltage or incorrect operation may result in an electric shock.

- Only connect the paper shredder to an alternating current supply with AC 220–240 V. Make sure that the voltage corresponds to the voltage data on the device.

- Only connect the paper shredder to an easily accessible socket so that you can quickly pull the power plug in an emergency.
- Do not operate the paper shredder if it is visibly damaged or if the power cord or power plug is defective.
- If the power cord of the paper shredder is damaged, the manufacturer, its After Sales Support or a person with similar qualifications must replace it.
- Do not open the housing. Instead, have repairs performed by a qualified expert. Contact a qualified workshop for this. Liability and warranty claims are waived in the event of repairs performed by the user, improper connection or incorrect operation.
- Only parts that comply with the original device data may be used for repairs. This device contains electrical and mechanical parts which are essential for providing protection against sources of danger.
- The paper shredder must not be operated with an external timer or separate telecontrol system.
- Do not submerge the paper shredder or the power cord in water or other liquids.
- Do not touch the power plug with damp or wet hands.
- Do not use the paper shredder if you are standing on wet ground or if your hands or the paper shredder are wet.
- When disconnecting the power plug from the socket, do not pull on the cord. Instead, pull directly on the plug.
- Never move, pull or carry the paper shredder by its power cord.
- Keep the paper shredder and power cord away from open flames and hot surfaces.
- Lay the power cord so that it does not pose a tripping hazard.
- Do not kink the power cord and do not lay it over sharp edges.
- Do not bend the power cord and do not wrap it around the paper shredder, as this may lead to a broken cord.

- 
- Only use the paper shredder indoors. Do not use the paper shredder in damp rooms or in the rain.
  - Never store the paper shredder such that there is a risk of it falling into a tub or a basin.
  - Never reach to retrieve an electrical device if it has fallen in water. In such a case, immediately disconnect the power plug.
  - Do not insert any objects in the housing.
  - Always switch the paper shredder off and unplug it when you are not using it, when you intend to clean it, or in the event of a malfunction.
  - Plug adapters or extension cords must also be equipped with a protective conductor.
  - Do not perform any other work (such as cleaning) on the paper shredder while it is operating.

** WARNING!**

**The paper shredder and its power cord must be kept away from children. Danger for persons with impaired physical, sensory or mental capacities (e.g. partially disabled persons, older persons with reduced physical and mental capacities) or lack of experience and knowledge.**

- If they are supervised or have been instructed in how to safely use the paper shredder and have understood the risks associated with operating it, this paper shredder may be used by persons with impaired physical, sensory or mental capacities or those lacking experience and knowledge.
- Ensure that children do not play with the paper shredder. It is not a children's toy.
- Do not let children use the paper shredder. Keep children away from the paper shredder and the power cord.
- Do not leave the paper shredder unattended while in operation.
- Keep the paper shredder away from pets.

- Ensure that children do not play with the plastic wrapping. Children may get caught in it when playing and suffocate.

**⚠WARNING!**

**Risk of injury!**

Handling the paper shredder improperly may result in injury.

- Do not reach into the feed slots with your hands.
- Keep long hair away from the feed slots.
- Keep ties, scarves, loose clothing, and long necklaces or bracelets away from the feed slots.
- Keep the feed slots away from aerosols.
- Set up the paper shredder in the vicinity of a properly installed socket. The socket must be freely accessible.
- Regularly remove any shredded paper and credit card residue from the underside of the cutting unit using a suitable tool (e.g. a brush).
- Always switch the paper shredder off and unplug the power plug before emptying the waste bins.
- After pulling out the waste bins, sharp and pointed parts of the cutting unit are exposed. Be careful.
- Lay the power cord so that it does not pose a tripping hazard.
- Only use the paper shredder when it is fully and correctly assembled.
- Never disassemble the paper shredder for cleaning or storage.

**NOTICE!**

**Risk of damage!**

Improper handling of the paper shredder may result in damage to the paper shredder.

- Place the paper shredder on an easily accessible, level, dry, heat-resistant and sufficiently stable work surface. Do not place the paper shredder on the edge of the work surface.

- 
- Protect the paper shredder from direct sunlight.
  - Never place the paper shredder on or near hot surfaces (e.g. stovetops, heaters etc.).
  - Ensure that the power cord does not come into contact with hot parts.
  - Do not operate the paper shredder for more than 3 minutes (for the manual paper feed slot) or 7 minutes (for the automatic paper feed slot). Let it cool down to room temperature before operating it again.
  - Do not drop paper clips or staples into the feed slots.
  - Do not compress the shredded paper in the waste bin with your hands or feet. The pressure could damage the waste bin.
  - Only insert paper or credit cards, but not other items into the paper / credit card feed slot.
  - Do not insert more than one credit card in the feed slot at a time. Otherwise the cutting unit could be irreparably damaged.
  - Empty the waste bins at regular intervals. If it overfills there is danger that shredded paper and credit card residue will be drawn up from underneath into the respective shredding system.
  - Never expose the paper shredder to high temperatures (heaters etc.) or to effects of the weather (rain etc.).
  - Only use the paper shredder at room temperature (approx. 10–25 °C).
  - Never fill the paper shredder with liquid.
  - Do not sit on the paper shredder and do not place any objects on the paper shredder.
  - Stop using the paper shredder if its plastic parts exhibit cracks or breaks or are deformed. Only replace damaged parts with corresponding original spare parts.

## First use

### Checking the paper shredder and pack contents

#### NOTICE!

#### Risk of damage!

If you are not cautious when opening the packaging with a sharp knife or other pointed object, you may quickly damage the paper shredder.

- Therefore, be very careful when opening the packaging.
1. Take the paper shredder out of the packaging.
  2. Make sure that all pack contents are present (see **fig. A**).
  3. Check whether the paper shredder or the individual parts exhibit damage. If this is the case, do not use the paper shredder. Contact the manufacturer at the service address specified on the warranty card.

### Assembly

#### ⚠ CAUTION!

#### Risk of injury!

Handling the paper shredder improperly may result in injury.

- During assembly, do not connect the paper shredder to a socket.
  - The main unit of the paper shredder has sharp edges. Be very careful when assembling the paper shredder.
1. Carefully remove the main unit **7** and the waste bin **10** from the packaging. Ensure that the fill level sensor **11** is located on the bottom of the main unit. Always be very careful when setting the main unit down. Otherwise the fill level sensor could be damaged or break off!
  2. Before first use, be absolutely sure to remove the adhesive strip serving as a transport guard from the fill level sensor. The fill level sensor must be folded down.

3. Remove also the cardboard cover of the cutting unit below the main unit.

Risk of injury! Do not touch the cutting unit as it is very sharp.

4. Place the main unit on the waste bin.

For transport, always carry the main unit by its carrying handles **9**.

Make sure that the safety contact **8** is fitted in the designated indentation on the back of the waste bin. You will hear a gentle click indicating that the main unit is correctly seated on the waste bin.

5. Then fold the cover lid **6**, also serving as a paper support, up.

You have now successfully assembled the paper shredder.

## Start-up

1. Make sure that the paper shredder is switched off (slide switch **5** in the **OFF** position) before connecting it to a socket.

2. Connect the power cord **2** to a socket.

3. Set the slide switch to the **AUTO** position.

The power LED (POWER) **14** will turn green and the paper shredder is now ready for use.

## Using the paper shredder

### **WARNING!**

### **Risk of injury!**

Handling the paper shredder improperly may result in injury.

- If an object (sleeves, tie etc.) is unintentionally taken into the paper feed slots, immediately disconnect the power plug.
- Hold both sides of the paper firmly when inserting it in the feed slot. Make sure that your fingers do not get too close to the feed slot.
- Hold the credit card by its narrow side when inserting it into the feed slot. Make sure that your fingers do not get too close to the feed slot.

**NOTICE!**

**Risk of damage!**

Improper handling of the paper shredder may result in damage to the paper shredder.

- The paper shredder is only intended for short operation and not for continuous operation. After an operating time of no more than 3 minutes for the manual paper feed slot and 7 minutes for the automatic paper feed slot, let the paper shredder remain idle for 60 minutes to prevent the paper shredder from overheating.
- Do not insert any damp paper in the feed slot. It could wrap around the cutting unit and cause a blockage.
- Do not feed paper with paper clips in the paper shredder. The cutting unit could be damaged.
- Avoid overloading the motor by not inserting more than 50 sheets (80 g / m<sup>2</sup>) in the automatic paper feed slot and no more than 7 sheets of paper (80 g / m<sup>2</sup>) in the manual paper feed slot.
- Avoid overloading the motor by never operating the automatic and manual paper feed slot at the same time.
- Only shred credit cards one at a time.
- Do not shred any formats larger than A4 or continuous paper.
- Do not use the manual paper feed slot to shred any paper smaller than credit card format.
- Do not use the automatic paper feed slot to shred any paper smaller than A5.
- Remove any staples and paper clips or similar before starting the shredding process.
- Unplug the power plug if the motor switches off due to overloading. Make sure that the slide switch is set to **OFF**. Let the motor cool down to room temperature for approx. 60 minutes before you insert the power plug back in the socket. Afterwards, you can continue with operation.





- The paper shredder has a safety contact **8**, which stops the operation of the paper shredder when it is activated. The safety contact is activated when the main unit has **7** not been completely inserted in the waste bin **10**. You will hear a click sound confirming that the safety contact is activated or deactivated.
- The paper sensor **17** is located on the left side of the paper feed slots (**1** and **4**) and aligned with the arrows for the sensor position **15**. It detects the paper that is fed in and activates the cutting unit in the paper shredder. For this reason, always insert smaller paper formats in the feed slot such that they are left aligned (minimal size: credit card, 85.60 mm × 53.98 mm).

## Automatic paper feed slot

With the automatic paper feed slot **1**, you can shred up to 50 sheets of paper (min. A5 to max. A4, 80 g / m<sup>2</sup>) at the same time.

- Feed up to 50 sheets of paper left aligned into the rear automatic paper feed slot (see **fig. B**).

The paper support **6** enables you to safely feed in paper without having to hold it during the shredding process.

- The paper shredder automatically switches on and draws in the paper. The shredding process will start after a delay of 7–10 seconds.

Approx. 1–2 seconds after processing the paper, the paper shredder will automatically stop.

## Manual paper feed slot

With the manual paper feed slot **4**, you can shred up to 7 sheets of paper (min. credit card format up to max. A4, 80 g / m<sup>2</sup>) at the same time.

- Feed up to 7 sheets of paper left aligned into the front manual paper feed slot (see **fig. C**).

- The paper shredder automatically switches on and draws in the paper.

Approx. 1–2 seconds after processing the paper, the paper shredder will automatically stop.

## Credit card feed slot

You can only feed one credit card into the paper shredder's credit card feed slot **4** for each shredding process.

- Always insert the credit card upright into the credit card feed slot (see **fig. D**). The arrow for the sensor position **15** of the credit card feed slot must always point to the middle of the credit card. The sensor for shredding credit cards is located here.
- The paper shredder automatically switches on and draws in the credit card. Approx. 1–2 seconds after processing the credit card, the paper shredder will automatically stop.

## Emptying the waste bin

### **WARNING!**

### **Risk of injury!**

Handling the paper shredder improperly may result in injury.

- Do not touch the cutting unit with your fingers.



For proper waste disposal, shred credit cards only when there is no processed paper in the waste bin. Only shred paper when there are no processed credit cards in the waste bin.

Empty the waste bin regularly to prevent paper or credit card residue from being drawn up from underneath into the cutting unit.

1. Switch the paper shredder off (move the slide switch **5** to the **OFF** position) and disconnect the power cord **2** from the socket.
2. Lift the main unit **7** off of the waste bin **10**.
3. Empty the waste bin.
4. Place the main unit back on the waste bin.

You must insert the main unit completely in the waste bin until you hear a click sound. This indicates that the safety contact **8** has been deactivated for normal operation.

# Paper or credit card jam

## WARNING!

### Risk of injury!

Handling the paper shredder improperly may result in injury.

- Never use objects of any kind to clear jammed credit cards or paper. Do not insert objects such as knives, scissors etc. into the feed slots.



To clear a jam:

1. Set the slide switch **5** to the **REV** position. The paper shredder runs in reverse direction.
2. The paper or credit card is discharged through the respective feed slot.
3. Allow the paper shredder to cool down to room temperature before you restart it.

### Fault LEDs

The paper shredder is equipped with fault LEDs. If one of these LEDs lights up, this indicates that there is a fault affecting the paper shredder.

Fault	Cause	Solution
The overload LED <b>14</b> (  ) is illuminated in red. The paper shredder will automatically switch off.	Too much paper or more than one credit card was fed into the cutting unit at the same time.	Set the slide switch <b>5</b> to the <b>REV</b> position. The cutting unit <b>12</b> will run in the reverse direction and push the paper back out of the paper feed slot. Reduce the amount of paper and switch back to <b>AUTO</b> .
	The manual and automatic paper feed slot has been operated at the same time.	Move the slide switch to the <b>OFF</b> position and disconnect the power cord <b>2</b> from the socket. Use the twist lock <b>3</b> to open the main unit <b>7</b> and then manually remove the paper residue (see chapter “Cleaning the cutting unit”).

Fault	Cause	Solution
<p>The overheat LED <b>13</b> () is illuminated in red. The paper shredder will automatically switch off.</p>	<p>The manual paper feed slot <b>4</b> was operated for longer than 3 minutes or the automatic paper feed slot <b>1</b> was operated for longer than 7 minutes.</p>	<p>Move the slide switch to the <b>OFF</b> position and disconnect the power cord from the socket. Only use the paper shredder after it has remained idle for at least 60 minutes.</p>
<p>The emptying LED <b>13</b> () is illuminated in blue. The paper shredder will automatically switch off.</p>	<p>The waste bin <b>10</b> has reached the maximum fill level.</p>	<p>Move the slide switch to the <b>OFF</b> position and disconnect the power cord from the socket. Lift the main unit off of the waste bin. Dispose of the paper residue with waste paper.</p>

## When not in use

If you do not use the paper shredder for a prolonged period of time, proceed as follows:

1. Set the slide switch **5** to the **OFF** position. The power LED (POWER) **14** will go out.
2. Disconnect the power cord **2** from the socket.

## Cleaning and maintenance

### **WARNING!**

#### **Risk of electric shock!**

Incorrect operation can cause an electrical shock.

- Before cleaning, always switch the paper shredder off and disconnect the power cord.

### **CAUTION!**

#### **Risk of injury!**

Improperly cleaning the paper shredder may result in injury.

- The paper shredder will become hot during operation. Let the paper shredder dry completely before you clean it.

- Do not touch the cutting unit with your fingers.

### NOTICE!

#### **Risk of short circuit!**

Water that has penetrated the housing may cause a short circuit.

- Make sure that no water or other liquids penetrate the housing.
- Do not submerge the paper shredder and the power cord in water or other liquids.

### NOTICE!

#### **Risk of damage!**

Handling the paper shredder improperly may result in damage.

- Do not use any aggressive cleaners, brushes with metal or nylon bristles, as well as sharp or metallic cleaning utensils such as knives, hard scrapers and the like. The surfaces of the paper shredder could be damaged as a result.

## **Cleaning the housing**

1. Move the slide switch **5** to the **OFF** position and disconnect the power cord **2** from the socket.
2. To clean the exterior of the paper shredder, use a dry or slightly moist, well-wrung cloth and let all parts thoroughly dry.

## **Cleaning the cutting unit**

For trouble-free operation, regularly and carefully remove any remaining paper and credit card residue from the cutting unit **12**.



1. Move the slide switch **5** to the **OFF** position and disconnect the power cord **2** from the socket.
2. Use the twist lock **3** to open the shutter for the main unit **16**. The holders on the shutter remain retracted as long as you hold the twist lock  open.
3. Fold the shutter for the main unit up. Now you can access the cutting unit.
4. Remove all paper and credit card residue from the cutting unit. Use suitable tools to do so (e.g. a paintbrush). Do not touch the cutting unit with your fingers.

We also recommend applying a small amount of special oil for paper shredders to the cutting unit. This will extend the service life of the device.

5. Then fold the shutter for the main unit back into the closed position. To do so, first turn the twist lock to the  symbol.

Make sure that the two holders on the shutter for the main unit lock back into the designated recesses in the paper shredder (on the left and right). Turn the twist lock back to the  symbol.

Keep in mind that the paper shredder does not start if the shutter for the main unit is not completely closed.

6. Take the main unit  off of the waste bin .
7. Remove all paper and credit card residue on the bottom of the cutting unit. Use suitable tools to do so (e.g. a paintbrush). Do not touch the cutting unit with your fingers.
8. Place the main unit back on the waste bin.  
You must insert the main unit completely in the waste bin until you hear a click sound. This indicates that the safety contact  has been deactivated for normal operation.
9. Connect the power cord with a socket again and set the slide switch to the **AUTO** position. You can now start the shredding process.

## Storage

1. Clean the paper shredder (see chapter “Cleaning and maintenance”).
2. Store the paper shredder in a clean, dry area. Never store the paper shredder next to a heat source.
3. Do not fold or crush the power cord .
4. Keep the paper shredder away from children.

## Troubleshooting



 **WARNING!**

### Risk of electric shock!

If you repair the paper shredder yourself or use unsuitable parts for repairs, you may increase the risk of electric shock.

- Never open the housing of the paper shredder. Instead, have repairs performed by a qualified professional. Contact a qualified workshop for this. Liability and warranty claims are waived in the event of repairs performed by the user or incorrect operation.

Some problems may be caused by minor faults, which you can rectify yourself. To do so, follow the instructions in the following table. If this does not correct the problem, contact the After Sales Support. Do not repair the paper shredder yourself.

Problem	Cause	Solution
The paper shredder switches off during operation. One of the fault LEDs (  /  /  ) is illuminated.	The paper shredder is overloaded or overheated.	See chapter “Fault LEDs”.
	The waste bin <b>10</b> has reached the maximum fill level.	
The paper shredder does not start when feeding in paper.	The paper may have been inserted at an oblique angle. The paper sensor <b>17</b> was therefore not activated.	Insert the paper left aligned into the paper feed slot <b>1</b> , <b>4</b> .
A paper jam occurs.	Too many sheets may have been fed in the paper shredder at a time.	Set the slide switch <b>5</b> to the <b>REV</b> position to clear the jam.
The paper shredder does not start.	The safety contact <b>8</b> is activated.	Make sure that the main unit <b>7</b> is completely inserted in the waste bin.
	The shutter for the main unit <b>16</b> is open.	Make sure that the shutter is completely closed.

## Technical data

Model:	AFS 21-A
Product code:	93915
Mains voltage:	AC 220–240 V/50 Hz
Power consumption:	350 watts; 1.5 A
Protection class:	II 
Safety class:	4 (in accordance with DIN 66399)
Weight:	approx. 5.2 kg
Dimensions (W × D × H):	321 × 263 × 444 mm
Waste bin volume:	21 litres
Working width:	220 mm (A4)

manual paper feed slot:	for credit card formats up to A4
automatic paper feed slot:	for A5 to A4
Cutting method:	Cross cut
Cutting speed:	2.1 m / min. (for max. 7 sheets, A4, 80 g / m <sup>2</sup> ) 3.5 m / min. (for 1 sheet, A4, 80 g / m <sup>2</sup> )
Cutting capacity (manual):	up to max. 7 sheets (80 g / m <sup>2</sup> ), max. 1 credit card per cycle
Cutting capacity (automatic):	up to max. 50 sheets (80 g / m <sup>2</sup> ) per cycle
Cutting format:	4 × 36 mm
Nominal operating time (manual):	3 minutes
Nominal operating time (automatic):	7 minutes
Nominal idle time:	60 minutes
Automatic start / stop function:	yes
Reverse function (REV):	yes

## Declaration of conformity



The EU declaration of conformity can be required from the address specified on the warranty card.

## Disposal

### Disposing of the packaging

- Sort the packaging before you dispose of it. Dispose of paperboard and cardboard with the recycled paper service and wrappings with appropriate collection service.

### Disposing of old appliances

#### **Old devices must not be disposed of with household waste!**

- Should the paper shredder no longer be capable of being used at some point in time, dispose of it in accordance with the regulations in force in your state or country.





office<sup>pro</sup>

**Paper Shredder with Automatic Feed**

## Warranty Details



---

The product is guaranteed to be free from defects in workmanship and parts for a period of 36 months from the date of purchase. Defects that occur within this warranty period, under normal use and care, will be repaired, replaced or refunded at our discretion. The benefits conferred by this warranty are in addition to all rights and remedies in respect of the product that the consumer has under the Competition and Consumer Act 2010 and similar state and territory laws.

Our goods come with guarantees that cannot be excluded under the Australian Consumer Law. You are entitled to a replacement or refund for a major failure and for compensation for any other reasonably foreseeable loss or damage. You are also entitled to have the goods repaired or replaced if the goods fail to be of acceptable quality and the failure does not amount to a major failure.

---

### AFTER SALES SUPPORT

  1300-728 116  
Free hotline

 [www.monolith-support.com](http://www.monolith-support.com)





office<sup>pro</sup>

Paper Shredder with Automatic Feed

## Repair and Refurbished Goods or Parts Notice

---

Unfortunately, from time to time, faulty products are manufactured which need to be returned to the Supplier for repair.

Please be aware that if your product is capable of retaining user-generated data (such as files stored on a computer hard drive, telephone numbers stored on a mobile telephone, songs stored on a portable media player, games saved on a games console or files stored on a USB memory stick) during the process of repair, some or all of your stored data may be lost.

**We recommend you save this data elsewhere prior to sending the product for repair.**

You should also be aware that rather than repairing goods, we may replace them with refurbished goods of the same type of use refurbished parts in the repair process.

**Please be assured though, refurbished parts or replacements are only used where they meet ALDI's stringent quality specifications.**

If at any time you feel your repair is being handled unsatisfactorily, you may escalate your complaint. Please telephone us on 1300-728 116 (Mon-Fri, 8:00-17:00) or write to us at:

monolith GmbH / CO Primegrafix Ltd

Unit 27



125-127 Highbury Road Burwood

Victoria

AUSTRALIA 3125

---

### AFTER SALES SUPPORT

  1300-728 116  
Free hotline

 [www.monolith-support.com](http://www.monolith-support.com)

**3**  
**YEARS**  
**WARRANTY**

ALDI guarantees that our exclusive brand products are developed to our stringent quality specifications. If you are not entirely satisfied with this product, please return it to the nearest ALDI store within 60 days from the date of purchase, for a full refund or replacement, or take advantage of our after sales support by calling the supplier's Customer Service Hotline.



### Made in China

office pro® is a registered trademark of ALDI Stores

DISTRIBUTED BY:

ALDI STORES

1 SARGENTS ROAD

MINCHINBURY NSW 2770

[www.aldi.com.au](http://www.aldi.com.au)

#### AFTER SALES SUPPORT

93915 



 **1300-728 116 (free)**



[www.monolith-support.com](http://www.monolith-support.com)

MODEL: AFS 21-A

01/17

**3**  
YEARS  
WARRANTY